

INTRODUCTION TO THE LATHE

by Eric Tilley and ed. by the NRG staff

The lathe is a wonderful tool, in fact without it the Industrial Revolution would never have happened. It does however need a bit of familiarity and practice in order to get some decent results out of it. It has to be said that most texts on lathe work relate to larger items of turning and are not applicable to our craft; hopefully these notes might be of use in addressing this.

Newcomers to the lathe might be a bit intimidated by it and by the fact you have to get up close and personal with an item which has unguarded chunks of metal flying round at many thousand RPM. But fear not, compared to other items of workshop machinery which can bite, get your hand too close to the chuck and it will knock your hand away without much damage. There are however basic safety rules which must be observed so please:

- 1) **Never ever leave the chuck key in the chuck** (the lathe operators golden rule). After using the key immediately put it back on the bench outside the work area, don't take your hand off the key while it is still in the chuck.
- 2) Wear close fitting clothing, no ties, scarves etc.
- 3) Take off any jewelery, especially necklaces, chains, bracelets and oversize rings.
- 4) Long hair? Tie it back well out of the way.
- 5) If you buy a second hand lathe check the cord and switch condition.
- 6) Buy a pair of large inexpensive reading glasses 2.5-3x magnification. These will allow you to keep a bit further away from the work piece and provide eye protection. Do not purchase anything stronger since the focal length is too short and the image becomes distorted at the periphery.
- 7) Keep your mind on what you are doing and if someone interrupts you **stop**.

Parts of the Lathe

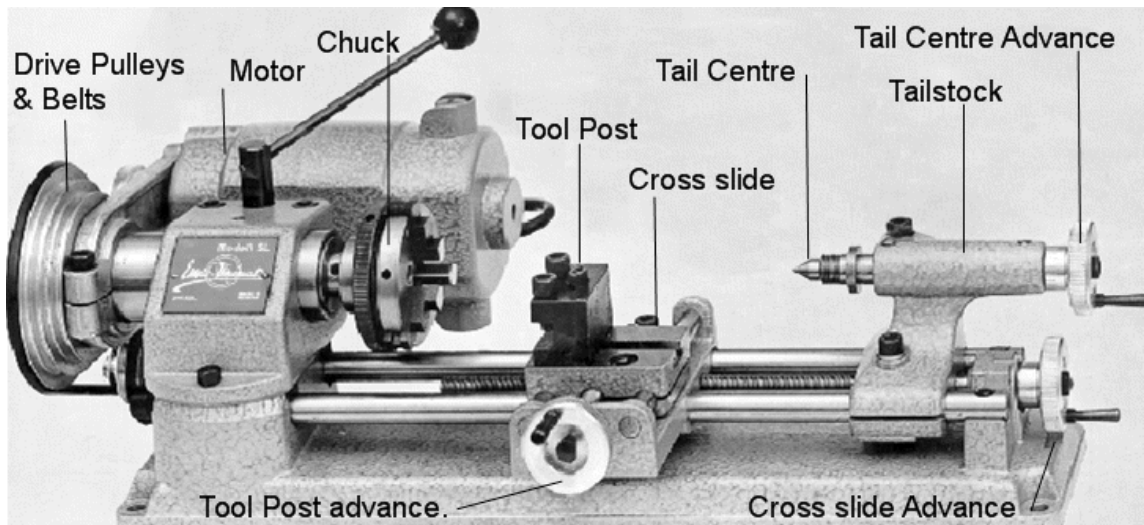

Lathe shown is the original Unimat SL(DB)

Chuck. Holds the work piece. Can be replaced with a Jacobs chuck or center for to hold the work.

Tailstock. Holds the tail center; it can be unlocked and slid towards the chuck.

Tail Center. Holds the end of longer pieces of work. (Small lengths can just be held in the chuck). The center can be replaced with a Jacobs chuck and drill rotating the advance wheel to drill the work.

Tool post. Holds the cutting tool.

Cross slide. Runs on the bed rails and has a mounting for the tool post which can be driven forward by the tool post advance wheel to bring the cutting tool to the work piece.

Cross slide advance. This moves the cross slide along the rails lengthwise and hence the cutting tool towards and away from the chuck.

Drive pulleys and belts. By varying the belt position on the pulleys various speeds of chuck rotation can be achieved. Modern lathes typically have a continuous variable speed adjustment.

Types of Lathes

Lathes can be categorized into four groups based on their usage.

- a) Jeweler's or watchmaker's lathes
- b) Hobby lathes, wood only
- c) Hobby lathes, capable of turning metal
- d) Industrial lathes, not discussed

Jeweler's or watchmaker's lathes as the name suggests are small machines often of a skeletal appearance and have a separate motor. They are capable of turning the smallest watch cogs and wheels. They do not usually have chucks but use collets to hold the work; these limit the diameter of work they handle. For anyone who wishes to turn very small items (less than 1/4") they would be ideal. However due to the high quality of the machine a good one will come at a high price.

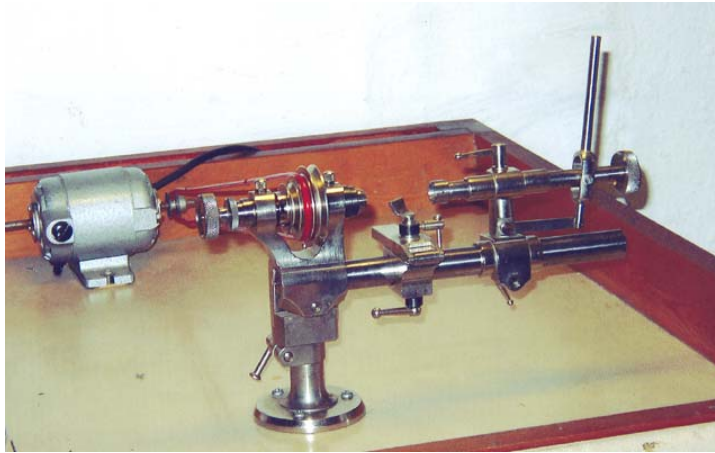

Hobby lathes are larger than jeweler's lathes. They are limited in capacity but can typically be able to turn up to 2-3" in diameter and up to 9" in length. They can be further categorized into lathes designed for turning wood, as seen below or wood and metal. These lathes run at lower rpm than the metal turning lathes.



[Metal-capable hobby lathes](#) are able to turn both wood and metal. They are more expensive and have many accessories available, including milling columns, rotary tables, indexing heads, etc. The cost of the accessories usually exceeds the cost of the lathe. These are serious, high-precision machines. The lathe illustrated below is manufactured by Sherline.



[Machine Condition](#)

Spend a little time ensuring your lathe is in good condition. Do not tolerate rust on any part. If there is any, remove it with 000 grade steel wool lubricated with light machine oil.

Take the chuck apart, remove the jaws and clean all the parts. Note that with the 3 jaw self-centering chuck each chuck slot and the jaw is stamped with a corresponding number 1-2-3. The jaws can be installed either with the projecting jaw innermost to hold small items or outermost to hold larger pieces. When installing the jaws to hold small pieces they are inserted in the sequence 1-2-3, and when holding large pieces the sequence is 3-2-1.

Clean and oil the cross slide and tailstock, ensuring that they they move freely.

While using the lathe, keep parts as free of debris as possible

Operating the Lathe

Make sure your tools are sharp. When turning small items like spindles a blunt tool will just push the piece away rather than cut. A small fine grinding wheel can be mounted in the lathe to sharpen the tool. Practice sharpening on an old tool first to get the feel of it. When doing this, put newspaper under the grinding wheel to stop hot grit from welding to the bed rail.

You will need a few different turning tools depending on the project. Right and left turning tools are used for forming the rings on cuts on cannon, for example. A pointed or planing tool can be used for general shaping. Other tools can be made as the need presents itself. There are many good sources for instructing how to make lathe tools.

Shown here are the right hand and pointed turning tools. They are made from HSS (high speed steel). Turning tools are available with tungsten steel tips and ceramic inserts but are not necessary for our work in wood and soft metals.



These are the grinding angles I use on my tools. Textbooks say that for brass the cutting angle should be nil, but I have about 1 degree and find that with this I can use the same tools for hardwood and for brass. After grinding I give the tools a bit of a polish to the cutting faces on an India oil stone.

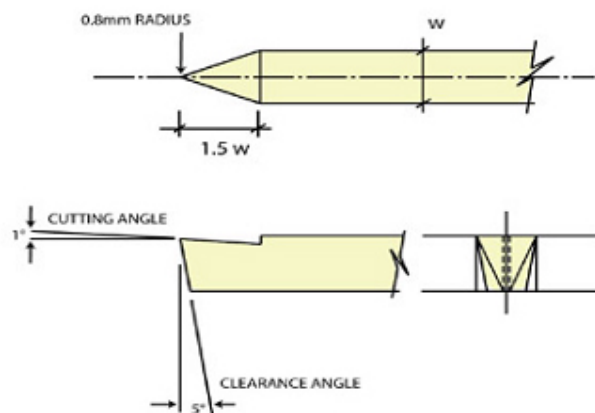

Each type of material has a different recommended turning speed. Unless your lathe is equipped with an rpm readout, the optimal turning speed will be determined by trial and error. Typical recommended turning speeds are:

Mild Steel.	1100rpm.
Brass	2000rpm
Hardwood	1600rpm

For mild steel a little paraffin brushed on will act as a lubricant and coolant, brass does not require lubricant unless the amount of material removed is causing heat build-up. In that case, light machine oil can be used.